

LICENSING SUB-COMMITTEE

Date: Friday 15 September 2017
Time: 10.00 am
Venue: Bad Homburg Room, Civic Centre, Paris Street, Exeter

Members are invited to attend the above meeting to consider the items of business.

If you have an enquiry regarding any items on this agenda, please contact Mark Devin, Democratic Services Officer (Committees) on 01392 265477 or email Mark.Devin@exeter.gov.uk

Entry to the Civic Centre can be gained through the Customer Services Centre, Paris Street.

Membership -
Councillors Hannan, Holland and Sills

Agenda

Part I: Items suggested for discussion with the press and public present

1 Appointment of Chair

To appoint a Chair for the meeting.

2 Declarations of Interest

Councillors are reminded of the need to declare any disclosable pecuniary interests that relate to business on the agenda and which have not already been included in the register of interests, before any discussion takes place on the item. Unless the interest is sensitive, you must also disclose the nature of the interest. In accordance with the Council's Code of Conduct, you must then leave the room and must not participate in any further discussion of the item. Councillors requiring clarification should seek the advice of the Monitoring Officer prior to the day of the meeting.

3 LOCAL GOVERNMENT (ACCESS TO INFORMATION) ACT 1985 EXCLUSION OF PRESS AND PUBLIC

To pass the following resolution:-

RESOLVED that, under Section 100A (4) of the Local Government Act 1972, the press and public be excluded from the meeting for items 5, 6 and 7 on the grounds that they involve the likely disclosure of exempt information as defined in paragraphs 1 and 2 of Part I of Schedule 12A of the Act.

LOCAL GOVERNMENT (MISCELLANEOUS PROVISIONS) ACT 1976

4 Application to renew private hire vehicle licence over 8 years old

To consider the report of the Environmental Health and Licensing Manager. (Pages 3 - 22)

Part II: Items suggested for discussion with the press and public excluded

LOCAL GOVERNMENT (MISCELLANEOUS PROVISIONS ACT 1976 TOWN POLICE CLAUSES ACT 1847

5 Application for the GRANT of a Hackney Carriage / Private Hire drivers licence. To determine if the Applicant is fit and proper

To consider the report of the Environmental Health and Licensing Manager. (Pages 23 - 40)

6 Application for the GRANT of a Hackney Carriage / Private Hire drivers licence. To determine if the Applicant is fit and proper

To consider the report of the Environmental Health and Licensing Manager. (Pages 41 - 50)

7 Application for the GRANT of a Hackney Carriage / Private Hire drivers licence. To determine if the Applicant is fit and proper

To consider the report of the Environmental Health and Licensing Manager. (Pages 51 - 62)

Individual reports on this agenda can be produced in large print on request to Democratic Services (Committees) on 01392 265107.

REPORT TO LICENSING (SUB) COMMITTEE

Time and Date of Hearing: 15 SEPTEMBER 2017 PART 1 Matter

Report of: Environmental Health and Licensing Manager

Type of Application: RENEWAL of a licence relating to a Private Hire vehicle over 8 years old.

Legislation: Local Government (Miscellaneous Provisions) Act 1976

Town Police Clauses Act 1847

Ward Application Refers to:

Not Applicable

Applicant: Mr Celestin NDE

Premises Address: Not Applicable

1. What is the report about?

- 1.1 An application has been received from Mr Celestin NDE, a licensed taxi driver seeking permission for the renewal of a private hire vehicle licence for a vehicle which is over 8 years old at the renewal date. This is a matter that cannot be dealt with under delegated powers.

2. Are there any representations?

- 2.1 There is no provision in the legislation for anyone to submit representations relating to this kind of application.

3. Report details:

- 3.1 The vehicle is a Toyota Prius registration number BD08 LHP. The vehicle has been licensed as a private hire vehicle since 23 August 2010. The date of the vehicle's registration is 9 May 2008 making the vehicle over 9 years old at the renewal date and therefore cannot be dealt with under delegated powers.

The vehicle is used as a Private Hire vehicle for Apple Central Cars, Exeter.

The existing policy in place regarding the renewal of private hire vehicles over 8 years old can be found at Appendix M Private Hire Licensing – Vehicle Specifications, M4, extracted from *(Practices and Procedures for the control of Hackney Carriage and Private Hire Vehicles, Drivers and Operators) November 2016. Exeter City Council.*

I would draw your attention to the following extract from the policy.

'Vehicles presented for renewal that are more than 8 years old will be referred to the licensing sub-committee for determination'.

- 3.2 The recorded mileage of the vehicle at the time of the last MOT (22 August 2017) was 256498 miles. The MOT is attached as a supporting document. You will note that the MOT has five advisories. The vehicle was inspected by an independent vehicle inspector on 22 August 2017 and the report is attached as a supporting document. The vehicle was inspected by a Licensing Officer on 24 August 2017 and appeared to be in a satisfactory condition. Photographs are attached of the bodywork and the interior of the vehicle as supporting documents.

4. What are the legal aspects?

- 4.1 Section 48(1) of the Local Government (Miscellaneous Provisions) Act 1976 ('the Act') states that a district council may on receipt of an application from the proprietor of any vehicle for the grant in respect of such vehicle of a licence to use the vehicle as a private hire vehicle, grant in respect thereof a vehicle licence:

Provided that a district council shall not grant such a licence unless they are satisfied-

a) that the vehicle is-

- i) suitable in type, size and design for use as a private hire vehicle;
- ii) not of such design and appearance as to lead any person to believe that the vehicle is a hackney carriage;
- iii) in a suitable mechanical condition;
- iv) safe; and
- v) comfortable;

b) that there is in force in relation to the use of the vehicle a policy of insurance or such security as complies with the requirements of Part VI of the Road Traffic Act 1988,

and shall not refuse such a licence for the purpose of limiting the number of vehicles in respect of which such licence are granted by the council.

- 4.2 Under Section 48(4)(c) of the Act the Licensing Sub-Committee may grant a licence for a maximum period of 12 months or such shorter period as they see as appropriate.
- 4.3 Any person aggrieved by a refusal of the Licensing Sub-Committee to grant a vehicle licence under Section 48 of the Act may appeal to the Magistrates Court within 21 days of receiving written notice of the refusal.

5. Recommendations:

- 5.1 The Licensing Sub-Committee are asked to determine the application having regard to current policy.

Environmental Health and Licensing Manager

Local Government (Access to Information) Act 1972 (as amended)

Background papers used in compiling this report:-

None

Contact for enquires:
Democratic Services (Committees)
Room 2.3
01392 265275

N.B THIS IS NOT PART OF THE REPORT

LOCAL GOVERNMENT (MISCELLANEOUS PROVISIONS) ACT 1976

HACKNEY CARRIAGE AND PRIVATE HIRE VEHICLE / DRIVERS LICENCES

You are invited to appear before the Licensing Sub-Committee to speak in support of your application. A legal or other adviser may accompany you but may not appear instead of you.

Your Application

Depending on the circumstances, your application may be heard in part two of the Committee meeting procedures from which members of the public and press are excluded. You will be notified in advance if your application will be a part two matter, if you have not been advised of this, the hearing will be in the Public domain.

You or your adviser would be expected to respond to an officer's verbal introduction outlining the above report. You or your adviser may be asked questions and may be invited to ask questions if appropriate.

At the end of the hearing you will be asked to withdraw and the Committee will reach a decision. On conclusion of the decision making process you will then be recalled and the decision announced.

This page is intentionally left blank



Driver & Vehicle
Standards
Agency

MOT Test Certificate

MOT Test Number

263293819519

Vehicle Registration Mark

BD08LHP

Vehicle Identification Number

JTDKB20UX07760056

Make

TOYOTA

Model

PRIUS

Colour

Blue

Issuer's Name

D. T. HEAGARTY

Test Class

4

Country of Registration

Great Britain

Expiry Date

21 August 2018 (EIGHTEEN)

Issued

22 Aug 2017

Test Station

77882

Odometer Reading and History

22 8 2017: 256498 mi
8 8 2016: 223937 mi
28 7 2015: 192754 mi
7 8 2014: 165256 mi

Inspection Authority

CENTRAL GARAGE SERVICES EXETER LTD
31-35 OLD TIVERTON ROAD
EXETER
EX4 6LG 01392 428088

Additional Information

To preserve the anniversary of the expiry date, the earliest you can present your vehicle for test is 22 July 2018.

Signature of Issuer

Advisory Information

- 001 Windscreen has damage to an area less than a 40mm circle outside zone A [B.B.1d]
- 002 Front (wipers poorly clearing screen) ✓
- 003 Rear (registration plate deteriorating) ✓
- 004 Front (headlamp lenses deteriorating resulting in a poor beam in 46-46-43)
- 005 Nearside Front (tyre wearing on outer edge)

REPAIRED
Dave S.



About this document

- 1 This document is a receipt style certificate telling you that an MOT Test pass result has been recorded in the Driver & Vehicle Standards Agency's (DVSA's) database of MOT Test results; this can be verified at www.gov.uk/check-mot-status.
 - 2 A test certificate relates only to the condition of the components examined at the time of test. It does not confirm the vehicle will remain roadworthy throughout the validity period of the certificate.
 - 3 Check carefully that the details are correct.
 - 4 Whilst advisory items listed above do not constitute MOT failure items, they are drawn to your attention for advice.
 - 5 For further information about this document, please visit www.gov.uk/getting-an-mot or contact DVSA on 0300 123 9000*.
- *Your call may be monitored or recorded for lawful purposes.

Comprehensive Vehicle Inspection Report

Customer Details

Exeter Motor Works
Old Tiverton Road
Exeter

Report Date: 22/08/17

Report No: 10421

Customer's contact details

Home:

Work: 01392 210739

Mobile: 07810825111

VEHICLE DETAILS

Make TOYOTA

Registration Number BD08 LHP

Model PRIUS T3 VVT-I

Colour Blue

Vehicle Identity Number (VIN) JTDKB20UX07760056

VIN Checked and confirmed
on vehicle
Yes X No

V5/Registration document
available and checked No

MOT Certificate available and
checked Yes

Mileage reading In 256502
(Not guaranteed) Out 256498

MOT Expiry Date 21/08/18

Vehicle Excise Licence Expiry 01/05/18

Date of inspection 22/08/17

Time of inspection 16:00

Location of vehicle Exeter Motor Works, Old Tiverton Road, Exeter.

Lighting Good

Weather. Good
(See notes)

Ramp available. Yes No
(See notes)

SECURITY CHECK

The vehicle identification number on this vehicle was checked and found to be **consistent** with the manufacturer's format.

SUMMARY REPORT

READY FOR USE – No faults found, suitable for immediate use.

ADVISABLE REPAIRS ONLY – Suitable for immediate use but advisable repairs should be planned for.

ESSENTIAL AND ADVISABLE REPAIRS REQUIRED – Not suitable unless all essential repairs are undertaken and advisable repairs, if any are planned for.

UNSATISFACTORY – Vehicle has significant deficiencies, which are judged to be impractical or uneconomical to repair to a satisfactory standard.

Please read all pages of this report

S satisfactory
 R repainted
 scratch
 X dent
 O corrosion
 C chip / rust
 P previous repairs

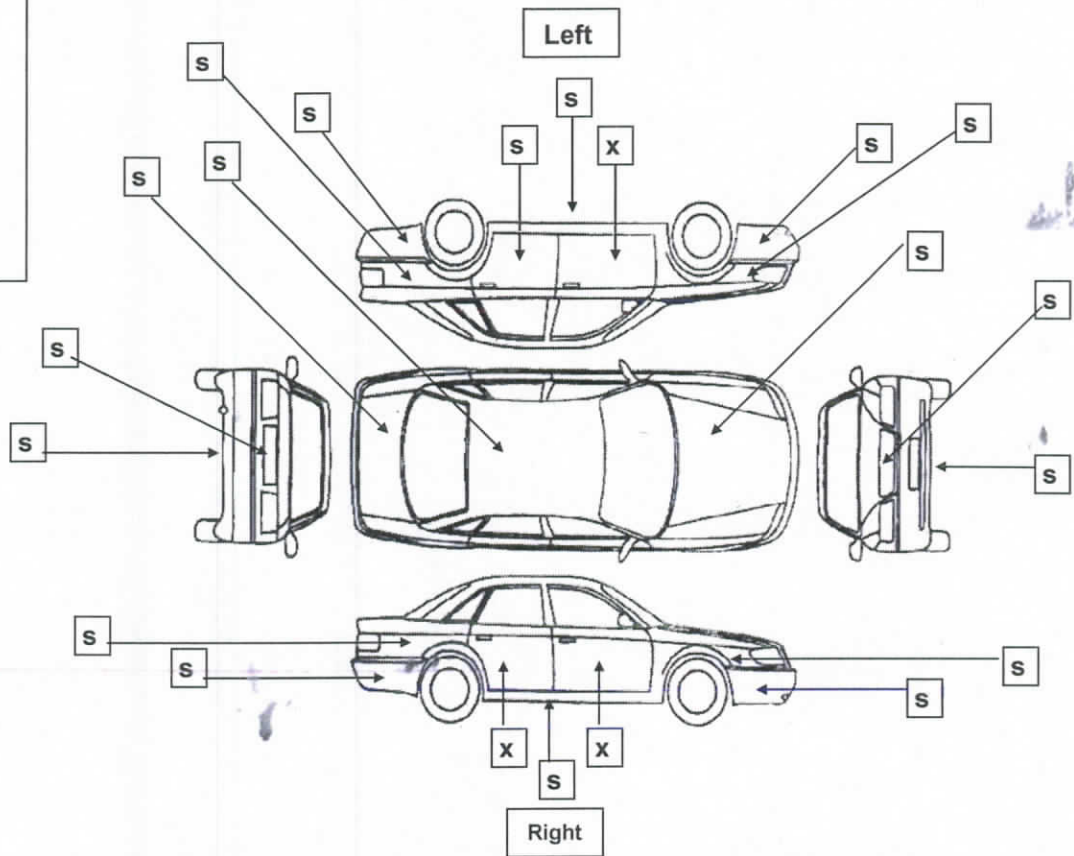

Minor blemishes, which are acceptable fair wear and tear for the vehicle's age, recorded mileage and type, are not recorded and you should satisfy yourself in this regard.

EVIDENCE OF BODYWORK REPAIRS Yes No
BODYWORK CLEAN AND DRY Yes No (See Notes)

Comments

The exterior body condition was good and commensurate with the vehicles age and recorded mileage.

KEY FOR POINTS ON FOLLOWING PAGES

S Satisfactory for age and recorded mileage
 -- Could not be checked
 x Essential repair requiring immediate attention
 A Advisable repair should be considered prior to purchase
 N/A Not applicable
 Y Yes
 N No

Please note: Right = Off side (O/S) and Left = Near side (N/S) as viewed from the driver's seat.

EXTERIOR

1. Wheel alignment	A	6. Door locks - operation	S	11. Mud flaps	S
2. Trim / grille	S	7. Fuel filler cover and cap	S	12. Body panels	S
3. Wipers / No plates - Ft / Rr	S	8. Soft top / Hard top (operation)	N/A	13. Bonnet catch	S
	A	9. Body damage	S	14. Bonnet hinges	S
	S	10. Corrosion	No		No

ENGINE COMPARTMENT

PETROL <input checked="" type="checkbox"/>		DIESEL MULTI-FUEL <input type="checkbox"/>		No. of CYLINDERS: 4	
15. Coolant Level / Condition	S	22. Power Steering - oil level	S	29. Turbo / supercharger	-
16. Coolant leaks	No	23. Clutch Fluid	S	30. Fuel pump / pipes	S
17. Antifreeze *	S	24. Brake Fluid	S	31. Accelerator linkage	S
18. Radiator / Cap	S	25. Engine Oil level	S	32. Cold starting	--
19. Hoses / Pipes	S	26. External leaks (upper engine)	S	33. Fast idle (cold)	--
20. Drive Belts	--	27. Engine mountings	S	34. Noise level (cold)	--
21. Water Pump (Not visible)	--	28. Fuel Injection	S	35. Excess fumes / smoke	No

Note - To ensure future serviceability, it is important that the engine camshaft belt is replaced at intervals specified by the manufacturer. It is in your best interests you ensure that this is carried out. * Antifreeze only has a 2/3 year life span and requires its strength adjusting after this time or replacing as per manufacturers specifications.

ELECTRICAL / CONTROLS

36. Starting system / Ignition lock	S	41. Rear lights & No. plate lights	S	49. Instruments	S
37. Battery condition	S	42. Stop lights	S	50. Horn	S
38. Battery voltages:	S	43. Indicator/ Hazard lights	S	51. Radio/Cass/CD/Aerial	S
- Normal 12.80 volts	S	44. Reverse / Fog lights	S	52. Heater / Fan controls	S
- Starting 10.55 volts	S	45. Auxiliary lights	N/A	53. Air Con operation	S
- Charging 14.40 volts	S	46. Interior / Panel lights	S	54. Windows / Sun roof	S
39. Headlights	S	47. Mirrors (electric)	S	55. Wipers / Washers	S
40. Sidelights / running lights	S	48. Controls / Switches	S	56. Headlamp wash / wipe	N/A

Note - We are unable to verify dash panel light and switch back lighting operation due to the daylight conditions. Please note that switching them "on or off" only assesses electrical components. Accuracy of instruments cannot be assessed.

INTERIOR / LUGGAGE COMPARTMENT

NUMBER OF SEATS: 5					
57. Steering Wheel / Adjustment	S	64. Door seals / hinges	S	71. Rear parcel shelf / load cover	--
58. Seat upholstery	S	65. Interior sills	S	72. Boot / tailgate lock	S
59. Seat adjustment	S	66. Headlining / visors	S	73. Luggage area trim con	S
60. Seatbelts	S	67. Sun roof	N/A	74. Illumination light	S
61. Carpets / Mats	S	68. Dash panel (condition)	S	75. Tool kit	S
62. Door trim panels	S	69. Cigarette lighter	N/A	76. Hard / Soft top (condition)	N/A
63. Door fittings / operation	S	70. Mirrors (internal)	S	77. Tonneau cover	N/A

FRONT SUSPENSION / STEERING / UNDER FRAME

78. Engine underside leakage	No	83. Wheel hubs / bearings	S	88. Sub-frames mountings	S
79. Steering joints/ ball joints	S	84. Springs/suspension units	S	89. Suspension arms / mountings	S
80. Steering rack / box	S	85. Pipes / hoses	S	90. Tie bars / anti roll bars	S
81. Chassis members	S	86. Dampers (condition / leaks)	S	91. Corrosion protection	Yes
82. Power steering (operation)	S	87. Gaiters	S	92. Corrosion - floor/chassis	No

REAR SUSPENSION / UNDER FRAME

93. Springs/suspension bars	S	97. Location rods/fixings	N/A	101. Sub-frames/ mountings	S
94. Anti roll bar	S	98. Bump stops/gaiters	N/A	102. Chassis members	S
95. Dampers/bushes	S	99. Wheel hubs/bearings	S	103. Corrosion protection	Yes
96. Suspension arms/fixings	N/A	100. Pipes/hoses	N/A	104. Corrosion - floor/chassis	No

CLUTCH / TRANSMISSION

MANUAL <input type="checkbox"/>		AUTOMATIC <input checked="" type="checkbox"/>		MULTI-USE / 4x4 <input type="checkbox"/>	
105. Fluid / oil leaks	No	109. Casings	S	113. Backlash	S
106. Cables / adjustments	N/A	110. Mountings	S	114. Gaiters	S
107. Hydraulic system	S	111. Drive shaft assembly	S	115. Propshaft(s) / fittings	N/A
108. Linkage (wear)	S	112. Universal / sliding joints	S	116. Bearings / supports	N/A

SYSTEM

S	120. Silencer(s)	S	123. System condition	S
S	121. Heat shields / mountings	S		
S	122. Joints / couplings	S		

FUEL SYSTEM

S	124. Tank	S	126. Fuel lines	S	128. Evidence of leaks	No
S	125. Tank fixings	S	127. Breather pipes	S		

BRAKES

S	129. Master cylinder security	S	132. Flexible hoses	S	135. Handbrake op / adjustment	S
No	130. Fluid leaks	S	133. Pipes / connections	S	136. Handbrake mechanism	S
S	131. Servo / power system	S	134. Discs / pads (if visible)	S	137. Pedal and pad / linkage	S

Note - If the vehicle is fitted with brake drums the internal parts including linings are not visible. Brake fluid should be replaced at the manufacturers specified intervals.

WHEELS AND TYRES Type: Alloy

It is recommended tyres be replaced when the tread depth reaches 2mm. If uneven tyre wear is noted, this may indicate incorrect geometry, which can result in excessive and rapid tyre wear. A full steering and geometry check is recommended.

138. Wheel Rims	S				
139. Wheel Trims	S				
		Make	Size	Type / Construction	Min tread depth
140. Front RH		Kumho	195/55/16	Radial	6.5mm S
141. Front LH		Autogrip	195/55/16	Radial	5.5mm S
142. Rear LH		Autogrip	195/55/16	Radial	5.5mm S
143. Rear RH		Autogrip	195/55/16	Radial	4.5mm S
144. Spare		Bridgestone	125/70/16	Space Saver Type	3.0mm S

145. ROAD TEST

The road test has been undertaken within the speed limits and prevailing traffic conditions in the locality of the inspection. If a road test has not been carried out, please refer to the engineer's comments page.

*If the vehicle is fitted with 4wd transmission then the systems have been checked for security, leakage and excessive noise. However, within the limitations of the road test the full functionality could not be checked.

Test Distance	3 Miles	Speed achieved up to 40 MPH			
146. Final drive operation / Noise level	S	153. Instrument /controls function	No	160. Road holding / stability	S
147. Gearbox operation / Noise level	S	154. Steering wheel alignment	S	161. General steering / handling	S
148. Engine performance	S	155. 4WD operation *	N/A	162. Footbrake operation	S
149. Engine noise	S	156. Clutch operation **	S	163. Hand/park brake operation	S
150. Excess smoke	No	157. Cooling fan operation	S	164. Suspension noise	No
151. Overheating evidence	No	158. Steering effort	S	165. Warning lights	S
152. Auto changes / kick-down	N/A	159. Hot restarting	S	166. Cruise control	S

** It should be carefully noted that the life expectancy of clutches is uncertain and difficult to predict, being dependant on owners driving style, vehicle operation and terrain. The fact that the clutch has not been identified as faulty/slipping/juddering/noisy on the report does not and should not be taken to imply that the clutch assembly will have a continuing life expectancy from the time of our check. They can begin to slip at any time.

FINAL CHECK

167. Oil leaks	No	168. Coolant leaks	No	169. Uneven tyre wear	No
----------------	----	--------------------	----	-----------------------	----

Report No: 10421

Engineers Comments

The vehicle is considered overall to be a fair and reasonable example of the type, being in a generally reasonable condition and generally considered to be consistent with the type for the age and indicated recorded mileage in most areas.

The items listed as "could not be checked" (---) normally indicate items were obscured by covers/shields or other equipment.

The Water pump – Engine drive belt/chain - these items could not been fully examined, as covers, trims and other equipment obscure them.

The cooling system was pressure tested to 0.7 bars, no pressure loss was noted on the system or pressure cap. The antifreeze concentration was an acceptable, but has deteriorated from its original strength and at the next routine service may need to be refreshed/replaced. It is advised that the coolant strength be checked again at the next routine service. Antifreeze only has a 2/3-year life and requires its strength adjusting after this time or replacing as per manufacturer's specifications.

The vehicle is fitted with vented front brake disc and pads, supported at the rear by a single arrangement. Although the visible brakes only show some signs of general serviceable wear, some deterioration is noted, which will need attention in the near future. It is strongly advised to remove all road wheels and examine the inner brake components, which are obscured on this vehicle prior to purchase, replacing any worn or badly corroded parts. It is probable that the front brakes at least, will need to be replaced at the next routine service.

The braking system's fluid contains the presence of some water/condensation in the system. It is recommended that the fluid content is completely replaced at the next service interval.

The steering & suspension has been assessed to MOT standard. This allows for a degree of wear and deterioration of components without rendering them unserviceable. The extent of wear is not considered excessive at this juncture and unlikely to attract MOT failure.

The road test distance and or top speed was limited due to the general area/inspection location, and/or traffic levels and/or adverse weather conditions and/or lack of fuel when the vehicle was tested and driven. Comment cannot be made in these instances in relation to possible "high speed" or "sustained speed," related driving defects, which may become apparent at a later stage after any purchase due to these limiting conditions.

Report No: 10421

Essential Repairs

It is strongly advised that the essential defects are investigated and rectified prior to purchase.

Item	Comment
------	---------

Additional Comments

No vehicle hoist/ramp was available. A large trolley jack and stands were used in order to carry out underside checks. This limits the view of the underside somewhat. Some areas could not be fully seen. There may be further defects, which may be visible given clear underside access and view.

The exhaust has been identified, as having limited life because, although there is no leakage present, there is some external corrosion present and the inside of the system, which may have significant deterioration, cannot be inspected internally.

Please note that a service is recommended, this may reveal repairs or maintenance requirements that could not be identified due to the constraints of a visual and external examination of the vehicle carried out without the benefit of a vehicle hoist.

Report No: 10421

Advisable Repairs

Please note that the advisable items may prove costly to repair, and must be considered.

Item	Comment
01	NSR Door has some damage, but does not affect it's operation.
04	Windscreen has some damage, but does not obscure the Driver's vision.

Additional Comments

The engineer was unable to verify dash panel light and switch back lighting operation due to the daylight conditions. Please note that switching them "on or off" only assesses electrical components. Accuracy of instruments cannot be assessed.

Although the radio operates when switched on, the full functionality of the in-car entertainment system has not been checked. This is beyond the scope of our inspections. You should ask the vendor to fully demonstrate the systems before purchase.

Report No: 10421

PLEASE READ CAREFULLY

- You are strongly advised to discuss the findings of this report with the vendor prior to making your decision to purchase the vehicle.
- Essential repairs should be investigated and rectified prior to purchase. These may be costly.
- Advisable repairs may prove costly to repair and must be considered prior to purchase.

Engineer's Name Phillip Bailey
Qualifications BSc Hons), M.I.M.I., AAE.



This page is intentionally left blank



This page is intentionally left blank



This page is intentionally left blank



This page is intentionally left blank

By virtue of paragraph(s) 1, 2 of Part 1 of Schedule 12A
of the Local Government Act 1972.

Document is Restricted

This page is intentionally left blank

By virtue of paragraph(s) 1, 2 of Part 1 of Schedule 12A
of the Local Government Act 1972.

Document is Restricted

This page is intentionally left blank

By virtue of paragraph(s) 1, 2 of Part 1 of Schedule 12A
of the Local Government Act 1972.

Document is Restricted

This page is intentionally left blank

By virtue of paragraph(s) 1, 2 of Part 1 of Schedule 12A
of the Local Government Act 1972.

Document is Restricted

This page is intentionally left blank

By virtue of paragraph(s) 1, 2 of Part 1 of Schedule 12A
of the Local Government Act 1972.

Document is Restricted

This page is intentionally left blank

By virtue of paragraph(s) 1, 2 of Part 1 of Schedule 12A
of the Local Government Act 1972.

Document is Restricted

This page is intentionally left blank

By virtue of paragraph(s) 1, 2 of Part 1 of Schedule 12A
of the Local Government Act 1972.

Document is Restricted

This page is intentionally left blank

By virtue of paragraph(s) 1, 2 of Part 1 of Schedule 12A
of the Local Government Act 1972.

Document is Restricted

This page is intentionally left blank

By virtue of paragraph(s) 1, 2 of Part 1 of Schedule 12A
of the Local Government Act 1972.

Document is Restricted

This page is intentionally left blank

By virtue of paragraph(s) 1, 2 of Part 1 of Schedule 12A
of the Local Government Act 1972.

Document is Restricted

This page is intentionally left blank

By virtue of paragraph(s) 1, 2 of Part 1 of Schedule 12A
of the Local Government Act 1972.

Document is Restricted

This page is intentionally left blank

By virtue of paragraph(s) 1, 2 of Part 1 of Schedule 12A
of the Local Government Act 1972.

Document is Restricted

This page is intentionally left blank